

Medium Garden Lodge Office pictured



WELCOME TO GARDEN EXTERIORS

We are a family owned and run business. Established in 1999, we are passionate about our unique Garden Structures and providing a personal service.

We are the only supplier of Authentic Arctic Structures in the UK. Every single one of our Garden Structures is meticulously handmade to order within the Arctic Circle just for you.

ALL OF OUR GARDEN STRUCTURES ARE:

- Manufactured in Sweden using time-honoured, traditional techniques passed down through generations of Scandinavian tradesmen.
- Made from sustainably sourced FSC Scandinavian Redwood so you can be confident they are eco-friendly.
- Built to withstand the severe climatic conditions of the Arctic Circle so they are warm in the winter and cool in the summer.

RETAIL PRICE LIST - STRUCTURES

Garden Stuga

Small	Garden Stuga.....	£11,300
	Garden Stuga Office.....	£11,300
Medium	Garden Stuga.....	£12,300
	Garden Stuga Office.....	£12,300
	Garden Stuga with single extension (Hip Roof).....	£16,300

Garden Lodges

Small	Garden Lodge.....	£9,850
	Garden Lodge with single extension (Hip Roof).....	£13,350
	Garden Lodge Office.....	£9,850
	Garden Lodge Office with single extension (Hip Roof).....	£13,350
Medium	Garden Lodge.....	£10,850
	Garden Lodge with single extension (Hip Roof).....	£14,850
	Garden Lodge Office.....	£10,850
	Garden Lodge Office with single extension (Hip Roof).....	£14,850
Large	Garden Lodge.....	£15,900
	Garden Lodge Office.....	£15,900

Extension starting from..... £5,300

Accessories

CP1 Catering Pack	£350
To include: a kettle arm, a manually operated fish/meat rotator, a pair of grill mitts, a teapot, a cooking rail, a set of cooking utensils, cast iron skillet and a saucepan arm.	
AC2 Authentic Reindeer Hide (each)	£150
AC3 Extended Fire Safety Guard	£150
AC4 External Log Box	£350
SP1 Set of Seat Pads	£450
DD1 Traditional Door Downgrade	£150
DU1 Full Length Double Glazed Door Upgrade (Lodges)	£150
TT1 Table Top Conversion (fits on top of cooking/heating unit. Suitable for small or medium structures)	£200
OW1 Extra opening Traditional window	£250
GE Gable roof extension upgrade	£500

Delivery direct from Sweden to anywhere in UK Mainland.....£1000

(Please note: All accessories are available to Garden Exteriors' customers but are subject to carriage charges if ordered separately to our structures. All prices inclusive of VAT).

Show Deal:

Medium Stuga pictured (standard front elevation)



THE UK'S SOLE SUPPLIER OF
THE GARDEN STUGA & AUTHENTIC ARCTIC STRUCTURES



AUTHENTIC GARDEN LODGES

Available in a range of sizes, our Garden Lodges are the perfect way to add that all-important family/work space but also a social place to meet.

Increase seating capacity by adding on one or more of our extensions or alter the layout of the door and windows to suit your outdoor space or personal circumstances.

Small garden lodge floor plan: (seating capacity - 10+)

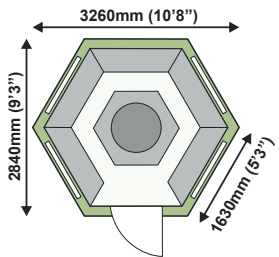

Medium garden lodge floor plan: (seating capacity - 15+)

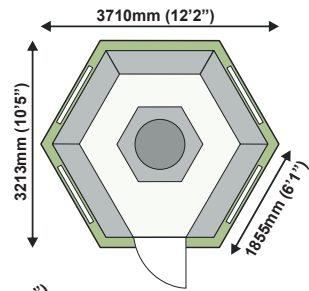

Medium garden lodge floor plan extension:

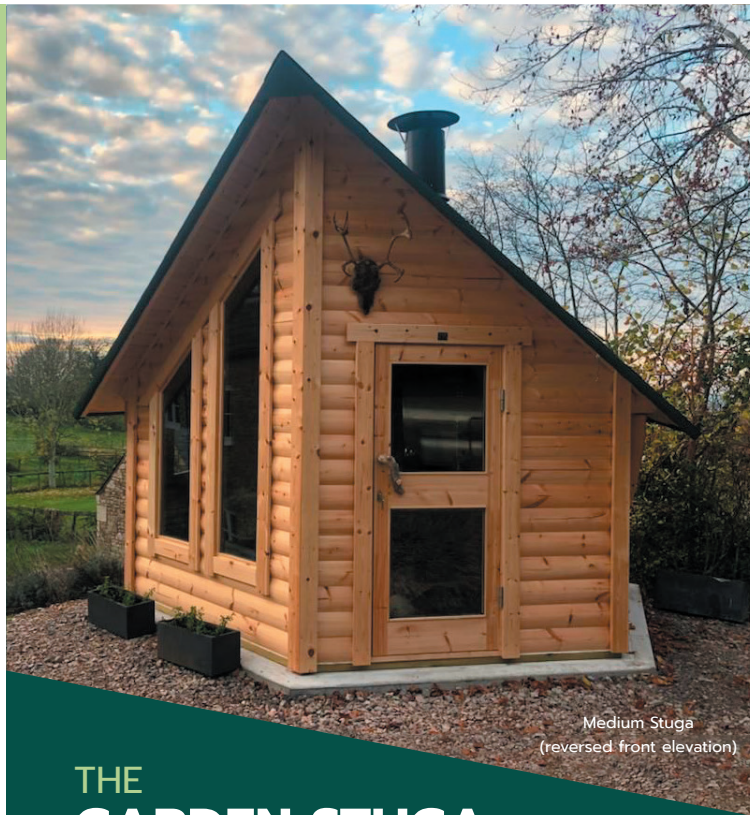
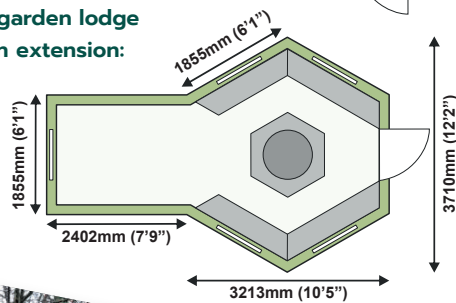

Medium Stuga
(reversed front elevation)

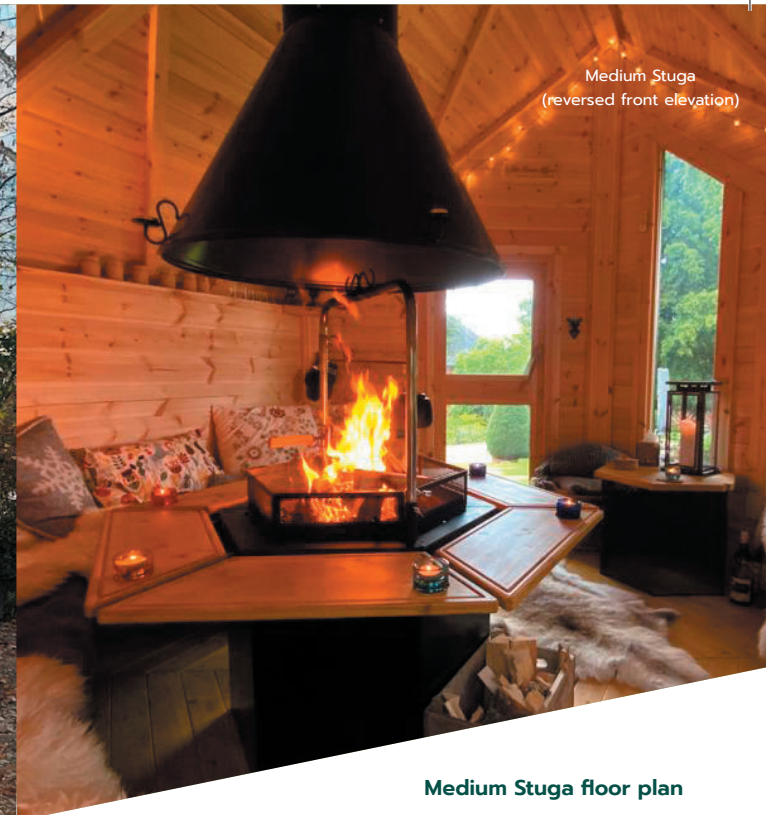

Medium Stuga
(reversed front elevation)

THE GARDEN STUGA

Exclusive to Garden Exteriors and with its striking contemporary lines, the Garden Stuga is perfect for 21st century outdoor living.

Built to the same exacting, traditional Arctic standards as our Garden Lodges & Rooms, the Garden Stuga has been specifically designed to maximise the natural light available via the two, stunning, double-glazed tinted picture windows.

Innovative design means that you lose none of the floor space and layout of the Garden Lodges and gain the sleek, modern look to complement your outside space and lifestyle.



The Stuga is fully protected by the EUIPO, it is not available through any other company or distributor. The Stuga range of buildings are fully protected by international law.

Garden Structures you can use all-year round.
(Medium Garden lodge pictured)

Small Stuga floor plan

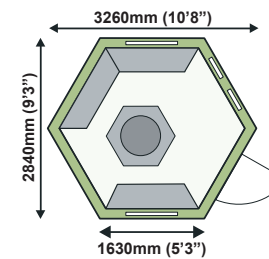

Medium Stuga floor plan

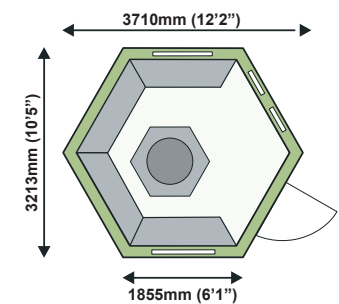

Medium Stuga floor plan extension

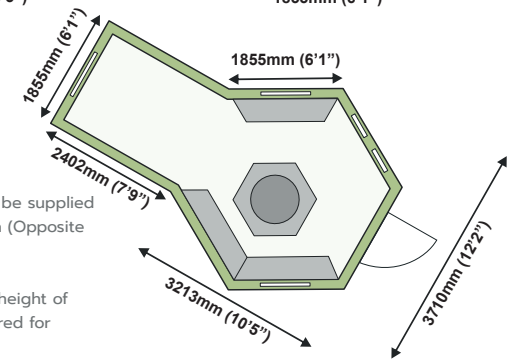

*Only 1 extension can be supplied with the Garden Stuga (Opposite door or tall windows)

*An access clearance height of 2135mm (7'0") is required for installation

Visit our website www.gardenexteriors.co.uk to find out more.
To visit our display area, please contact us to arrange an appointment.